

## A20-SOM AND A20-SOM-4GB

System-on-Module boards capable of Linux and Android boot

### USER'S MANUAL

Document revision I, March 2015

Designed by OLIMEX Ltd, 2015



All boards produced by Olimex LTD are ROHS compliant

## DISCLAIMER

---

© 2015 Olimex Ltd. Olimex®, logo and combinations thereof, are registered trademarks of Olimex Ltd. Other product names may be trademarks of others and the rights belong to their respective owners.

**The information in this document is provided in connection with Olimex products. No license, express or implied or otherwise, to any intellectual property right is granted by this document or in connection with the sale of Olimex products.**

The hardware designs of A20-SOM and A20-SOM-4GB development boards are considered intellectual property to Olimex. The hardware design files are considered copyright material and would not be distributed.

The hardware design of A20-SOM-EVB development board is considered open source hardware. The source design files are published online and accessible by everyone.

The software is released under GPL.

It is possible that the pictures in this manual differ from the latest revision of the board.

The product described in this document is subject to continuous development and improvements. All particulars of the product and its use contained in this document are given by OLIMEX in good faith. However all warranties implied or expressed including but not limited to implied warranties of merchantability or fitness for purpose are excluded. This document is intended only to assist the reader in the use of the product. OLIMEX Ltd. shall not be liable for any loss or damage arising from the use of any information in this document or any error or omission in such information or any incorrect use of the product.

This evaluation board/kit is intended for use for engineering development, demonstration, or evaluation purposes only and is not considered by OLIMEX to be a finished end-product fit for general consumer use. Persons handling the product must have electronics training and observe good engineering practice standards. As such, the goods being provided are not intended to be complete in terms of required design-, marketing-, and/or manufacturing-related protective considerations, including product safety and environmental measures typically found in end products that incorporate such semiconductor components or circuit boards.

Olimex currently deals with a variety of customers for products, and therefore our arrangement with the user is not exclusive. Olimex assumes no liability for applications assistance, customer product design, software performance, or infringement of patents or services described herein.

**THERE IS NO WARRANTY FOR THE DESIGN MATERIALS AND THE COMPONENTS USED TO CREATE A20-SOM, A20-SOM-4GB AND A20-SOM-EVB. THEY ARE CONSIDERED SUITABLE ONLY FOR A20-SOM, A20-SOM-4GB AND A20-SOM-EVB, RESPECTIVELY.**

## Table of Contents

<b><u>DISCLAIMER.....</u></b>	<b><u>2</u></b>
<b><u>CHAPTER 1: OVERVIEW.....</u></b>	<b><u>5</u></b>
<b><u>1. Introduction to the chapter.....</u></b>	<b><u>5</u></b>
<b><u>1.1 Introduction to SOM (System-On-a-Module).....</u></b>	<b><u>5</u></b>
<b><u>1.2 Target market of the board.....</u></b>	<b><u>6</u></b>
<b><u>1.3 Features of A20-SOM.....</u></b>	<b><u>6</u></b>
<b><u>1.4 Board variants.....</u></b>	<b><u>7</u></b>
<b><u>1.5 Board versions used in the manual.....</u></b>	<b><u>7</u></b>
<b><u>1.6 Document organization.....</u></b>	<b><u>7</u></b>
<b><u>CHAPTER 2: SETTING UP THE A20-SOM BOARD.....</u></b>	<b><u>8</u></b>
<b><u>2. Introduction to the chapter.....</u></b>	<b><u>8</u></b>
<b><u>2.1 Electrostatic and electrical polarity warnings.....</u></b>	<b><u>8</u></b>
<b><u>2.2 Requirements.....</u></b>	<b><u>8</u></b>
<b><u>2.3 Powering the board.....</u></b>	<b><u>9</u></b>
<b><u>2.3.1 Stand-alone powering.....</u></b>	<b><u>9</u></b>
<b><u>2.3.2 Mounted powering.....</u></b>	<b><u>10</u></b>
<b><u>2.4 Button functions.....</u></b>	<b><u>10</u></b>
<b><u>2.5 Interacting with the board.....</u></b>	<b><u>11</u></b>
<b><u>2.6 Expanding the Debian file system space.....</u></b>	<b><u>12</u></b>
<b><u>2.7 Changing the default image resolution.....</u></b>	<b><u>12</u></b>
<b><u>2.8 Connecting and calibrating a display.....</u></b>	<b><u>15</u></b>
<b><u>2.8.1 Android calibration.....</u></b>	<b><u>16</u></b>
<b><u>2.8.2 Debian calibration.....</u></b>	<b><u>16</u></b>
<b><u>2.9 Software support.....</u></b>	<b><u>17</u></b>
<b><u>CHAPTER 3: BOARD DESCRIPTION.....</u></b>	<b><u>18</u></b>
<b><u>3. Introduction to the chapter.....</u></b>	<b><u>18</u></b>
<b><u>3.1 Layout (top view).....</u></b>	<b><u>18</u></b>
<b><u>CHAPTER 4: THE ALLWINNER A20 MICROCONTROLLER.....</u></b>	<b><u>19</u></b>
<b><u>4. Introduction to the chapter.....</u></b>	<b><u>19</u></b>
<b><u>4.1 The processor.....</u></b>	<b><u>19</u></b>
<b><u>4.2 Block diagram.....</u></b>	<b><u>20</u></b>
<b><u>CHAPTER 5: CONTROL CIRCUITY.....</u></b>	<b><u>21</u></b>
<b><u>5. Introduction to the chapter.....</u></b>	<b><u>21</u></b>
<b><u>5.1 Reset.....</u></b>	<b><u>21</u></b>
<b><u>5.2 Clocks.....</u></b>	<b><u>21</u></b>
<b><u>5.3 Power supply circuit.....</u></b>	<b><u>21</u></b>
<b><u>CHAPTER 6: CONNECTORS AND PINOUT.....</u></b>	<b><u>22</u></b>
<b><u>6. Introduction to the chapter.....</u></b>	<b><u>22</u></b>
<b><u>6.1 Communication with A20-SOM in Linux.....</u></b>	<b><u>22</u></b>

---

<b>6.2 UART0 pins.....</b>	<b>22</b>
<b>6.3 MicroSD card connector.....</b>	<b>23</b>
6.3.1 SD/MMC slot.....	23
<b>6.4 Power pins for external power supply.....</b>	<b>24</b>
<b>6.5 GPIO connectors.....</b>	<b>24</b>
6.5.1 GPIO-1 (General Purpose Input/Output) 40pin connector.....	25
6.5.2 GPIO-2 (General Purpose Input/Output) 40pin connector.....	26
6.5.3 GPIO-3 (General Purpose Input/Output) 40pin connector.....	27
6.5.4 GPIO-4 (General Purpose Input/Output) 40pin connector.....	28
6.5.5 GPIO-5 (General Purpose Input/Output) 40pin connector.....	29
6.5.6 GPIO-6 (General Purpose Input/Output) 10pin connector.....	29
<b>6.6 LCD CON 40pin connector.....</b>	<b>30</b>
<b>6.7 Jumper description.....</b>	<b>31</b>
<b>6.8 Additional hardware components.....</b>	<b>31</b>
<b>CHAPTER 7: SCHEMATICS.....</b>	<b>32</b>
<b>7. Introduction to the chapter.....</b>	<b>32</b>
<b>7.1 Eagle schematic.....</b>	<b>32</b>
<b>7.2 Physical dimensions.....</b>	<b>32</b>
<b>CHAPTER 8: REVISION HISTORY AND SUPPORT.....</b>	<b>33</b>
<b>8. Introduction to the chapter.....</b>	<b>33</b>
<b>8.1 Document revision.....</b>	<b>33</b>
<b>8.2 Board revision.....</b>	<b>34</b>
<b>8.3 Useful web links and purchase codes.....</b>	<b>35</b>
<b>8.4 Frequently asked questions.....</b>	<b>37</b>
<b>8.5 Product support.....</b>	<b>41</b>

---

## CHAPTER 1: OVERVIEW

---

### 1. Introduction to the chapter

---

Thank you for choosing this single board computer from Olimex! This document provides a user's guide for the A20-SOM board. As an overview, this chapter gives the scope of this document and lists the board's features. The document's organization is then detailed.

The A20-SOM development board enables code development of applications running on the A20 microcontroller, manufactured by Allwinner Technology from China.

The A20-SOM is typically used together with A20-SOM-EVB which features most of the peripherals and connectors needed for full evaluation and utilization of the A20 processor.

The hardware design of A20-SOM development board is considered intellectual property to Olimex. The hardware design files are considered copyright material and would not be distributed.

A20-SOM-EVB board is an open-source, open-hardware project and all documentation is available to the customer.

The software support for both boards is open-source and released under GPL license.

### 1.1 Introduction to SOM (System-On-a-Module)

---

OLIMEX System-on-Module (SOM) boards are powerful Linux-capable boards. They follow a low-cost modular design which allows rapid product development. Each of these boards has two parts – a main part which nests the processor, the memory and the power control unit and the peripheral part which contains the USB ports, the video output and most of the connectors. SOM designs are targeted at customers who want to apply custom modifications and own solutions based on a specific processor without having to deal with multi layer PCBs with controlled impedance and BGA assembly. This makes it possible to create simple boards (that might be manufactured by your local board manufacturer) containing only the peripherals you need with the dimensions and shape suitable for your specific solution.

Both the main part and the peripheral part of the SOM system have support in the official Android and Debian images distributed by Olimex and maintained by Olimex and the Linux community. These images are typically available at the wiki articles of the boards.

The peripheral part of the SOM design is considered Open Source HardWare (OSHW) and the customer has access to the board source files that we used to manufacture it. The part of the design that has the main microcontroller is considered proprietary design and design files would not be shared. If you are looking for open source design of the processors used please check the OLinuXino boards. OLinuXino board designs are fully open source but harder to implement in own solutions and require more of a hardware experience to do so. Nevertheless, OLinuXino boards are pretty good choice for evaluating the capabilities of the embedded processors.

---

## 1.2 Target market of the board

---

Using the A20-SOM as a stand-alone development board would be more suitable for users with some hardware experience or people already familiar with other single-board Linux boards and designs. As mentioned in the previous chapter the board is meant to be implemented in a hardware design.

In which cases a stand-alone A20-SOM (without A20-SOM-EVB) board might not be suitable for you:

1. If you are a beginner with single-board Linux computers
2. If you are an OSHW purist
3. If you are looking for more straight-forward software development and you are not going to implement the A20-SOM in own hardware products

In the cases above, it might be a better idea to take a look at the OLinuXino boards (like A20-OLinuXino-MICRO).

It is highly recommended to use A20-SOM with A20-SOM-EVB initially, unless you have previous experience with SOM or OLinuXino boards manufactured by OLIMEX.

A20-SOM might be used altogether with A20-SOM-EVB. In that case, the board's target market widens drastically – the combination is suitable for embedded programming enthusiasts, Linux and Android gadget fans (they can just use the board as a media center or fully functional Linux-PC, for instance) and also professionals (since its low cost makes it very good solution for application-orientated embedded systems). The reason for this alteration is the additional hardware that A20-SOM-EVB – it provides direct HDMI output and easier ways to connect peripherals to the board. Generally, the processors features are much easier to access.

---

## 1.3 Features of A20-SOM

---

The A20-SOM board has the following set of features:

- Allwinner A20 dual core Cortex-A7 processor, each core typically running at 1GHz
- 1GB DDR3 memory
- AXP209 PMU IC
- **4GB NAND FLASH memory (available only on the 4GB version of the board)**
- **Android already loaded on the NAND (available only on the 4GB version of the board)**
- MicroSD card
- UART console
- Status LEDs
- RESET, RECOVERY buttons
- 6 connectors x 40 pin each x 0.05" step
- PCB dimensions: (3200×2200)mil ~ (81×56)mm

## 1.4 Board variants

---

There are two major board variants named: A20-SOM and A20-SOM-4GB. The 4GB version has built-in NAND memory that allows the storage of an operating system without the need of a SD card (at the moment of writing this document Olimex provides only Android OS for the NAND). The 4GB version comes with already programmed and ready-to-use Android OS image.

The other Olimex board with close characteristics is A13-SOM board. It is much cheaper and smaller. It heats less and consumes less power. However, it features a generation older processor and lesser amount of RAM memory, making it less desirable for heavy computations (for instance, high resolution video decoding and encoding).

Other SOM boards that might be compared to functionality are the and quad-core ARM Cortex-A9 RK3188-SOM and the BeagleBone-inspired AM3352-SOM.

## 1.5 Board versions used in the manual

---

The documents follows the hardware layout of A20-SOM board revision D. There might be revision B pictures left over.

Note that major changes in the hardware design were introduced in A20-SOM board revision C. Boards from the initial couple of revisions have visible differences compared to boards from revisions C and on. Yet, the two major functional differences are the improved memory clock speed (480MHz compared to the initial 384MHz) and the presence of the additional GPIO-6 connector. It is important to notice that different board revision might use different Debian images!

A20-SOM-EVB revision C peripheral board was used while writing this document.

Different board revisions might have different features or settings. It is possible that parts of this document do not apply to all board revisions.

## 1.6 Document organization

---

Each section in this document covers a separate topic, organized as follows:

- Chapter 1 is an overview of the board usage and features
- Chapter 2 provides a guide for quickly setting up the board and software notes
- Chapter 3 contains the general board diagram and layout
- Chapter 4 describes the component that is the heart of the board: the A20 – Allwinner processor
- Chapter 5 is an explanation of the control circuitry associated with the microcontroller
- Chapter 6 covers the connector pinout, peripherals and jumper description
- Chapter 7 provides the schematics and the dimensions of the board
- Chapter 8 contains the revision history, useful links and support information

---

## CHAPTER 2: SETTING UP THE A20-SOM BOARD

---

### 2. Introduction to the chapter

---

This section helps you set up the SOM development board for the first time. Please consider first the electrostatic warning to avoid damaging the board, then discover the hardware and software required to operate the board.

The procedure to power up the board is given, and a description of the default board behavior is detailed.

#### 2.1 Electrostatic and electrical polarity warnings

---

A20-SOM boards are shipped in a protective anti-static package. The board must not be exposed to high electrostatic potentials. A grounding strap or similar protective device should be worn when handling the board. Avoid touching the component pins or any other metallic element.

Ensure that your development board gets attached to properly working hardware. If this is not possible please use isolators (like USB-ISO) to save your development board from potential over voltage.

If you connect other electrical devices to the SOM board make sure that they have equal electrical polarity. For example, when you connect a serial cable connected between a PC and the board's DEBUG port it is a good idea to have them both connected to the same electrical source (to the same utility power socket). In rare cases different polarity might cause hardware damage to the board.

#### 2.2 Requirements

---

In order to set up the A20-SOM board optimally one or more additional items may be needed. They might be generally placed in two categories:

**Required** – items that are needed in order to achieve minimum functionality;

**Recommended** – items that is good to have in order to be able to interact with the most important of the features of the board;

Note that if A20-SOM is mounted on A20-SOM-EVB – the requirements would be different! The requirements below are for a stand-alone use of A20-SOM. Refer to A20-SOM-EVB's user's manual for adjusted requirements.

**Required items:**

- 5V-external power supply with proper connectors – A20-SOM has no power jack, only powering pins (5VEXT, GND)
- Output device – USB-SERIAL-CABLE-F + personal computer with serial terminal program – A20-SOM lacks other options for debugging – you would need a serial cable that can work at the CMOS levels of the board's signals
- SD card with compatible image – if you have the board version with NO additional NAND



memory you will need it to use one of the images available. If you decide to use Debian you would also need a card. Official Android and Debian images are available at the wiki article for the board.

**Recommended items:**

- **A20-SOM-EVB** – reference design of a 2-layer board for A20-SOM which adds VGA, HDMI, Audio in/out, LCD, 2 MP camera, Gigabit Ethernet, SATA, USB-OTG and 2 USB hosts. The A20-SOM-EVB board also adapts the 0.05" step GPIO headers to 0.1" step headers so you can easily attach an LCD or UEXT module. Its hardware design is open source and available as Eagle CAD files, so everyone can modify and tailor it according to the specific needs.

Some of the above-suggested items can be purchased by Olimex, for instance:

**USB-SERIAL-CABLE-F** – female USB serial console cable – provides the easiest way of debugging

**A20-SOM-REV-D-DEBIAN-SD** – a tested, class 10 micro SD card suitable for A20-SOM boards revision C or newer; with latest (by the time of leaving the Olimex facilities) official Debian release

**A20-SOM-DEBIAN-SD** – a tested, class 10 micro SD card suitable for A20-SOM boards revision A and revision B; with latest (by the time of leaving the Olimex facilities) official Debian release

**A20-SOM-ANDROID-SD** – a tested, class 10 micro SD card with the latest (by the time of leaving Olimex facilities) official Android release

## 2.3 Powering the board

---

The powering requirements of the A20-SOM are different depending on whether you use it in stand-alone mode or mounted atop A20-SOM-EVB. The sub-chapters below deal with both scenarios.

### 2.3.1 Stand-alone powering

---

If you use the board in stand-alone mode (e.g. it is neither attached to A20-SOM-EVB nor to any other board of peripherals) there are fewer options for powering it. Consider that you might need additional cables or connectors. You have the following options of powering the board:

1. +5V via UART0 header – requires external 5VDC power source
2. 5VEXT via GPIO-2 (5VEXT pin #1; GND pin #2) and GPIO-4 (5VEXT pin #1; GND pin #2) – requires external 5VDC power source
3. BAT via GPIO-2 (BAT pin #3; GND pin #4) – requires external 4.2VDC battery
4. +5V\_OTG\_PWR via GPIO-1 (+5V\_OTG\_PWR pin #5; GND pin #2) – requires external 5VDC driven by any USB

The default way of powering the board is using external power supply. In that case you would need to provide 5V DC at the 5VEXT pin of UART0 connector. You would also need to connect the GND pin of the same connector to the GND line of you supply. The minimum power that your supply should be able to prove is 2.5W (equivalent of 0.5A of current at 5V of voltage). Note that there is no standard jack for the powering circuit but you might add own DC power jack.

**Do not provide AC voltage to the A20-SOM board! Do not provide more than 5V of voltage directly to the A20-SOM board! Providing 12V would instantly cause permanent hardware damage!**

Sometimes when starting Android it is possible the board to enter battery save mode even before booting fully. Especially, if you have turned off the board without quick boot mode enabled. In this case you should press the PWR button for at least 5 seconds which would allow the board to start. Furthermore, if the board has entered power-down state you can bring it back without restart using either the RECOVERY or the PWR\_BUT.

### 2.3.2 Mounted powering

---

Typically, A20-SOM gets evaluated when mounted on A20-SOM-EVB. In this case the former is powered via the latter. The power line, altogether with a number of other important processor lines, is transferred via the 40-pin headers. A20-SOM receives power from A20-SOM-EVB, but what are the requirements to power A20-SOM-EVB?

You need to provide 6V to 16V DC voltage to the power jack (named PWR) of A20-SOM-EVB board. The DC barrel jack has 2.0mm inner pin and 6.3mm hole. More information about the exact component might be found here: <https://www.olimex.com/wiki/PWRJACK>

Do not provide AC voltage to the A20-SOM-EVB board! Do not provide more than 16V of voltage to the A20-SOM-EVB board!

The typical consumption of A20-SOM-EVB + A20-SOM is between 150mA @ 12V and 250mA @ 12V depending on the processor's current load.

For the European customers, we also stock and sell basic power supply adapters compatible with the power jack.

The default username/password combination for the default Linux image on the SD card (if purchased) is: root/olimex.

Note that it is normal that when the board is powered some integrated circuits might appear hotter than others. This is perfectly normal for some chips – for instance – the voltage regulators and the main processor.

## 2.4 Button functions

---

The three buttons listed bellow are supported under both Android and Debian:

**PWR\_BUT** – used to perform software turn off, software turn on; used to turn on board when powered by battery – has to be held down for at least 5 seconds to perform each action

**RECOVERY** – used to wake up the board from sleep

**RESET** – used for hardware reset of the board – before using it, please refer to the note below

It is recommended to always make a soft “turn off” of the board. If that is not possible then please hold PWR button down for a few seconds to “turn off the board”. Then you are free to remove the power supply.

If you disconnect the power supply (either the USB, the battery or the power jack) before turning off the board you may corrupt your SD card. If your board has NAND memory you can corrupt the image located on the NAND memory.

## 2.5 Interacting with the board

---

The typical and recommended way of interacting with A20-SOM board is via a serial cable connected between the UART-DEBUG header and a personal computer. You would probably need a cable suitable for such a connection due to the fact that most personal computers lack a serial port nowadays. Even if you have serial port you should respect the CMOS levels of the board which are incompatible with the TTL levels of your computer. We distribute a ready-to-use plug-and-play cable – it is called USB-SERIAL-CABLE-F. Even if you already have such a cable or you decide to purchase it elsewhere it is advisable to check this product page for a reference:

<https://www.olimex.com/Products/Components/Cables/USB-Serial-Cable/USB-Serial-Cable-F/>

You need to connect the serial cable lines as follows: RX line to UART0-TX pin; TX line to UART0-RX pin; GND to GND. Make sure that the serial cable is connected to your personal computer and recognized properly after driver installation.

After the hardware connection is established, open a terminal program on the serial (COM) port which the cable is associated with. The typical baud rate is 115200, the rest of the settings should be left as per default.

After everything else is set, you would need to power the board as explained in “2.3 Powering the board”.

In the command line interface of the official Debian images you are automatically logged as root. The default superuser username/password combination in the GUI (LXDE) of the official images is: olimex/olimex

If the A20-SOM is attached to A20-SOM-EVB, in addition to the serial communication, you might also use one or more of the following mediums to interact with the board:

1. a monitor via HDMI connector
2. a monitor via the VGA connector
3. SSH via the mini USB connector through a mini USB cable
4. SSH with a remote computer via LAN connector
5. a display via LCD\_CON connector

Refer to the A20-SOM-EVB's datasheet for more information on each connection.

Note that not all interface options are available for all images. Furthermore, some of the ways of interaction are not suitable for Android OS. The official Debian image should give you the most possible options of interfacing the board!

Using HDMI, LCD\_CON or LAN might require additional configurations. Furthermore, it is possible to corrupt the output settings over those interfaces and, thus, lose the output. In such cases, you can always use the serial cable USB-SERIAL-CABLE-F as a reliable way to establish connection to the board.

---

## 2.6 Expanding the Debian file system space

---

The provided official Debian images have constant size but you may want to use a bigger microSD card.

In case you don't know how to expand the file system space you can use the built-in shell script for this task. This way you can take advantage of the whole volume of your microSD card.

Type in the command prompt:

```
./resize_sd.sh /dev/mmcblk0 1
```

After that you need to reboot the board with:

```
reboot
```

You can find the name given to the microSD card and its partition using:

```
fdisk -l
```

---

## 2.7 Changing the default image resolution

---

The method for changing the output video resolutions varies whether you are using Android or Debian.

To ease the process of changing the resolution we have compiled a number of Android images for the Android users (with hard-coded video output settings). Alternatively, for Debian Linux users, we have provided a shell script that can be executed in order to set preferred video output and resolution.

For Android that you boot from the NAND memory you would need an image suitable for the specific resolution. Download locations to such images might be found at the wiki article for the A20 board here: <https://www.olimex.com/wiki/A20-SOM>.

For Linux Debian you would need to execute a shell script to be able to change the resolution. It is very good idea to use a serial cable for connection to the board from a personal computer since in this case you are not dependent on the current video output resolution (a cable like USB-SERIAL-CABLE-F). When the board boots type:

```
./change_display*
```

or

```
./change_display_a20_SOM.sh
```

It looks like this:

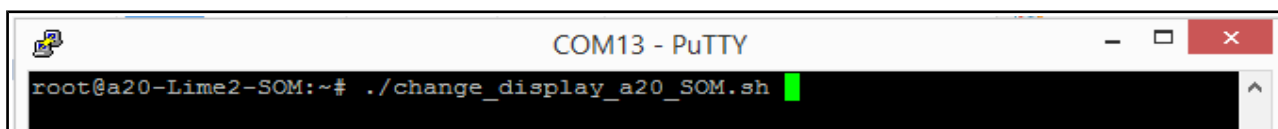

```
COM13 - PuTTY
root@a20-Lime2-SOM:~# ./change_display_a20_SOM.sh
```

Then the main menu of the video configuration script shows up:

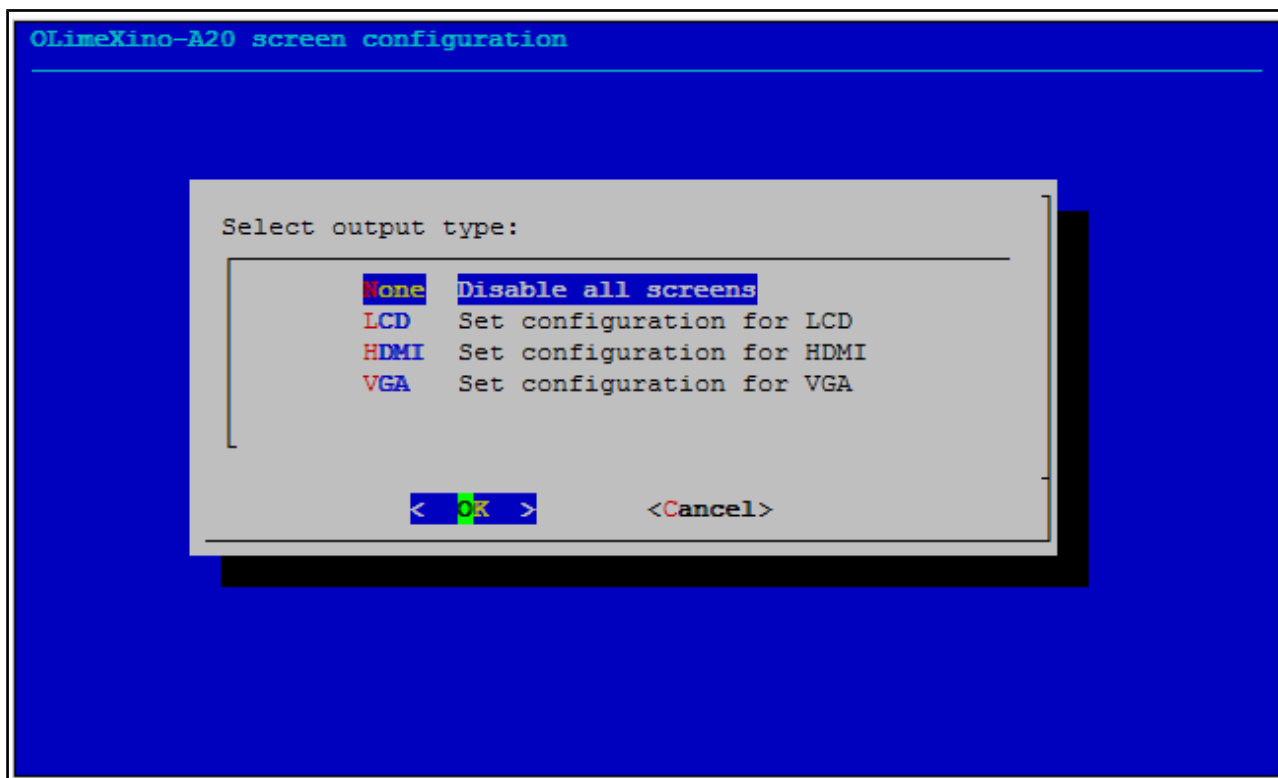

Choose the resolution and the interface (LCD, HDMI or VGA).

The supported resolutions are listed on the next page.

For LCD:

1. 4.3" (480×272)
2. 7" (800×480)
3. 10" (1024×600)

For HDMI:

0. 480i
1. 576i
2. 480p
3. 576p
4. 720p50
5. 720p60
6. 1080i50
7. 1080i60

8. 1080p24
9. 1080p50
10. 1080p60

For VGA (VGA is available out-of-the-box only in the A20-SOM + A20-SOM-EVB combination, else additional hardware is required):

0. 1680×1050
1. 1440×900
2. 1360×768
3. 1280×1024
4. 1024×768
5. 800×600
6. 640×480
7. 1920×1080
8. 1280×720

Depending on the display or the screen you want to use with the A20-SOM, you might need to apply software changes to the prebuilt Android or Linux image. The easiest way would be to do it on the board itself but it can be done offline too (manipulating the image located on the microSD card via a microSD card reader).

The tools for script.bin changing are located in /opt/sunxi-tools directory:

```
cd /opt/sunxi-tools
./chscr.sh
```

This will convert script.bin file from sdcad to script.fex file and the file will be opened using nano editor. Now you can change the board modules and parameters, save the changes ("CTRL"+"X"; confirm with "Y") and exit ("CTRL"+"X" again) from nano editor.

```
./wrscr.sh
```

this will convert script.fex to script.bin and the script.bin file will be written to the microSD card.

```
reboot
```

Reboot the board and the new settings would be enabled.

For the Debian Linux releases, this means that you would need to edit the configuration file script.bin and edit the settings inside. This file is usually located in the main partition of a prepared microSD card. Script.bin can't be opened in the binary format so you would need to convert it to .fex file format first. There are ready-to-use tools that convert script.bin <-> script.fex. Note that script.bin/fex contains configuration settings and definitions not only for the video output but also for the pin descriptions and names; power setting and much more. If you really want to modify and customize the default images (to change port functions, port names, to disable specific peripherals) you would need to be able to edit the script files. Please refer to the following web page for more information: [http://linux-sunxi.org/Fex\\_Guide](http://linux-sunxi.org/Fex_Guide)

The typical A20-SOM user would not need to edit the files, however.

## 2.8 Connecting and calibrating a display

One of the ways to interact with the board is via an external display (with or without touchscreen component). However, there is only a 40-pin female connector LCD\_CON with a 0.05" step.

Unlike other OLIMEX Allwinner boards, the A20-SOM lacks a row of pins that allows the user to connect a display out-of-the-box. The board's LCD\_CON connector is female and has a smaller 0.05" step. This means that if you use a display made by OLIMEX, you would need additional 2×20 MALE-MALE 0.05" header to convert the female connector to male. The 0.05" headers are somehow hard to find so we sell them here: [0.05" step connectors](#).

Newer displays made by Olimex have both 0.1" and 0.05" step connectors. Going for an LCD output you would also need need a compatible cable to attach the display to the board. The cable is sold separately.

The displays recommended for the board at the moment of writing might be found in the table below:

Display name	Size of display in inches	Native resolution in pixels	Official Debian image support	Official Android image support	Link to product page
LCD-Olinuxino-4.3TS	4.3	480×272	Yes	No	<a href="#">Product page</a>
LCD-Olinuxino-7	7	800×480	Yes	Yes	<a href="#">Product page</a>
LCD-Olinuxino-7TS	7	800×480	Yes	Yes	<a href="#">Product page</a>
LCD-Olinuxino-10	10.1	1024×600	Yes	Yes	<a href="#">Product page</a>
LCD-Olinuxino-10TS	10.1	1024×600	Yes	Yes	<a href="#">Product page</a>
LCD-Olinuxino-15.6	15.6	1366×768	Yes	No	<a href="#">Product page</a>
LCD-Olinuxino-15.6FHD	15.6	1920×1080	Yes	No	<a href="#">Product page</a>

The displays whose names contain "TS" - include a resistive touch screen component.

The cable used for connection depends on the specific board you are using and more specifically it depends on the pitch of the LCD connector of the board. We have two cables – both 40-pins ones but one for the bigger pitch (0.1") and the other for the smaller one (0.05"). Each of the displays listed in the table above has two connectors suitable for both cables:

CABLE-IDC40-15cm – 15cm long cable suitable for 0.1" step connectors – [Product page](#)

CABLE-40-40-10CM – 10cm long cable suitable for 0.05" step connectors – [Product page](#)

### 2.8.1 Android calibration

---

Calibrating a display under Android is pretty straightforward from the Android application.

Important: initially the boards are calibrated for a specific display and resolution. If you re-write the image (no matter whether the SD card or the NAND memory) you might need to use a mouse to calibrate the display initially. It might be impossible to calibrate it only by using the touch component over the display.

### 2.8.2 Debian calibration

---

The command that allows calibrating in Debian Linux is:

```
ts_calibrate
```

The default Debian setup is made with settings for HDMI 720p/60Hz. If you want to change some other LCD, VGA or HDMI resolution then you have to start script file in /root directory.

If the problem is under Debian Linux make sure you are properly logged in the LXDE interface! Else applying calibration would not happen for the current user – if you are calibrating from the X graphical interface make sure that you are logged as user “olimex” (if calibrating without the X, the user is “root”).

```
#su olimex
```

```
enter the password: olimex
```

```
calibrate the touch screen and reboot the board
```

```
#sudo reboot
```



## 2.9 Software support

---

We maintain Linux and Android images for SD card which might be downloaded for free and modified as the user wishes. The latest images and updates are featured at the wiki article of the device: <https://www.olimex.com/wiki/A20-SOM>.

We usually try to provide details on how to build the Linux and the Android images at our wordpress page: <http://olimex.wordpress.com/>.

Another useful place is the Olimex forums where a lot of people share their experience and advice: <https://www.olimex.com/forum/>.

The official images are a constant work-in-progress – newer releases are packed with better hardware support, newer kernels and extra features.

You are more than welcome to send or share your suggestions and ideas at our e-mail, the public forums or irc channel. We would attempt to help in almost every case. We listen to the feedback and if the majority of users suggest a software change or update we try to implement such. Customer feedback is very important for the overall state of the software support. However, do not expect full Linux or Android software support.

We can share our experience. We can give you full details for things we have tried. We can point you to a resource or a guide. We can give you general directions to solving a specific problem or places to look for more information. However, we won't install a piece of software for you or write custom program for you. We won't provide a specific software solution to a specific software problem.

## CHAPTER 3: BOARD DESCRIPTION

### 3. Introduction to the chapter

Here you get acquainted with the main parts of the board. Note the names used on the board might differ from the names used below to describe them. For the actual names check the A20-SOM board itself.

#### 3.1 Layout (top view)

The picture below shows the top side of the A hardware revision of board and highlights the most important parts:

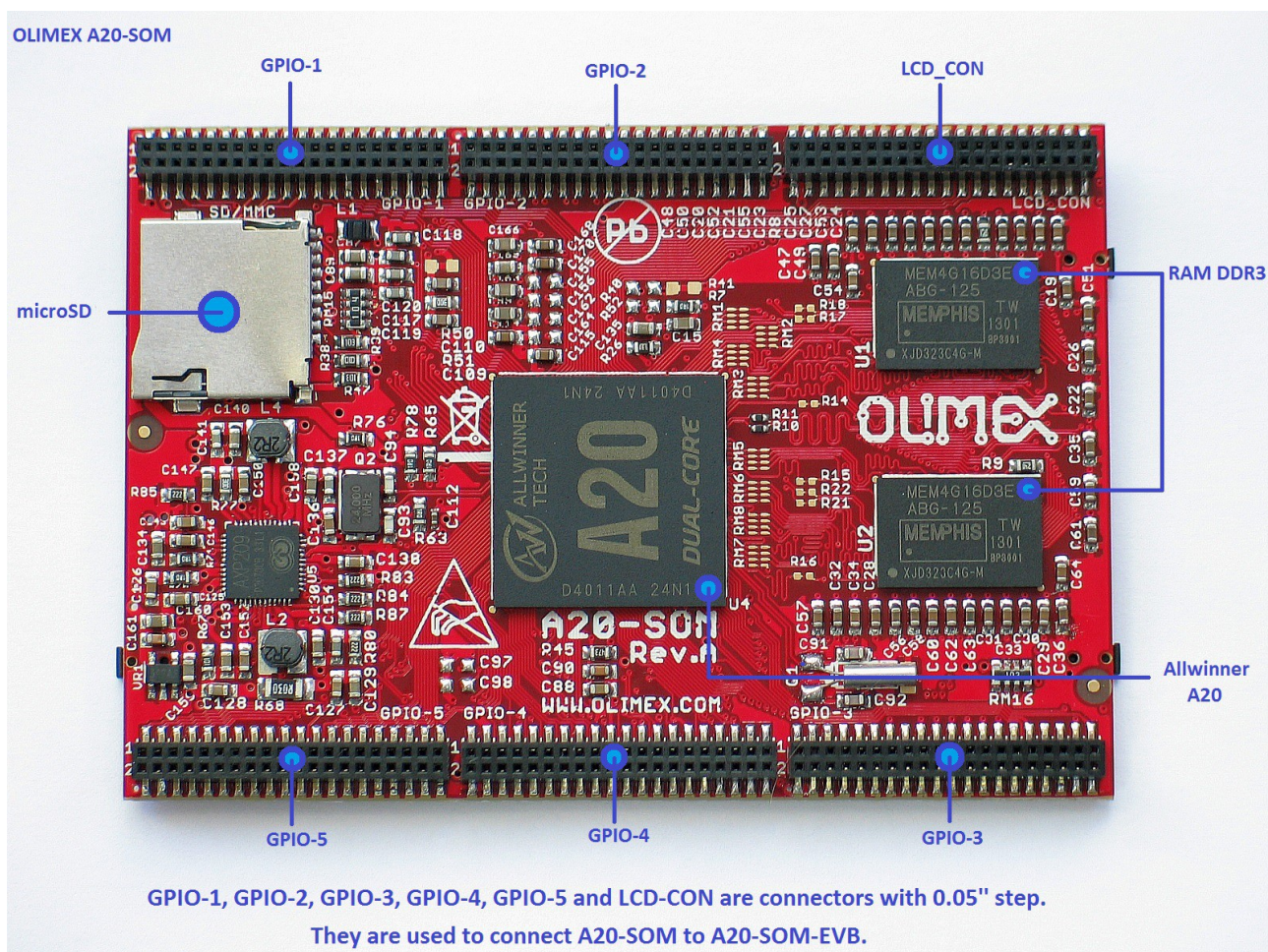

Please note that there might be differences in the layout of top of the board compared to the latest revision. One of the notable changes introduced in hardware revision C of the design, is the addition of GPIO-6 row of pinholes that provides easier access to some additional pins. The general routing and memory positions are also adjusted.

---

## CHAPTER 4: THE ALLWINNER A20 MICROCONTROLLER

---

### 4. Introduction to the chapter

---

In this chapter is located the information about the heart of A20-SOM – its microcontroller. The information is a modified version of the datasheet provided by its manufacturers.

#### 4.1 The processor

---

The main feature of the A20 processor is the sheer computing power that allows FullHD video playback. The graphical processing unit is also pretty powerful and supported by the default software packages that come with the SOM boards. The software support for the features in the processor is at pretty good state thanks to the efforts of the community and Allwinner themselves.

The full list of features might be found below:

- CPU
  - ARM® Cortex™-A7 Dual-Core
- GPU
  - ARM® Mali400MP2
  - Complies with OpenGL ES 2.0/1.1
- VIDEO
  - HD H.264 2160p video decoding
  - Multi-format FHD video decoding, including Mpeg1/2, Mpeg4 SP/ASP GMC, H.263, H.264,
  - VP6/8, AVS jizun, Jpeg/Mjpeg, etc.
  - H.264 High Profile 1080p@30fps or 720p@60fps encoding
  - 3840×1080@30fps 3D decoding, BD/SBS/TAB/FP supported
  - Complies with RTSP, HTTP, HLS, RTMP, MMS streaming media protocols
- DISPLAY
  - Supports multi-channel HD display
  - Integrated HDMI 1.4 transmitter with HDCP support
  - CPU/RGB/LVDS LCD interface
  - Supports CVBS/YPbPr/VGA
  - Integrated TV decoder
- CAMERA
  - Integrated parallel 8-bit I/F YUV sensor
  - Integrated 24-bit parallel YUV 444 I/F
  - Supports 5M CMOS sensor
  - Supports dual sensors
- MEMORY
  - DDR2/DDR3/DDR3L controller
  - NAND Flash controller with 64-bit ECC

- AUDIO
  - Integrated HI-FI 100dB Audio Codec
  - Dual analog mic amplifiers

More information can be found on Allwinner's web site at the following web-address:  
<http://www.allwinnertech.com/en/clq/processor/A20.html>

## 4.2 Block diagram

The block diagram is taken from Allwinner's web-site.

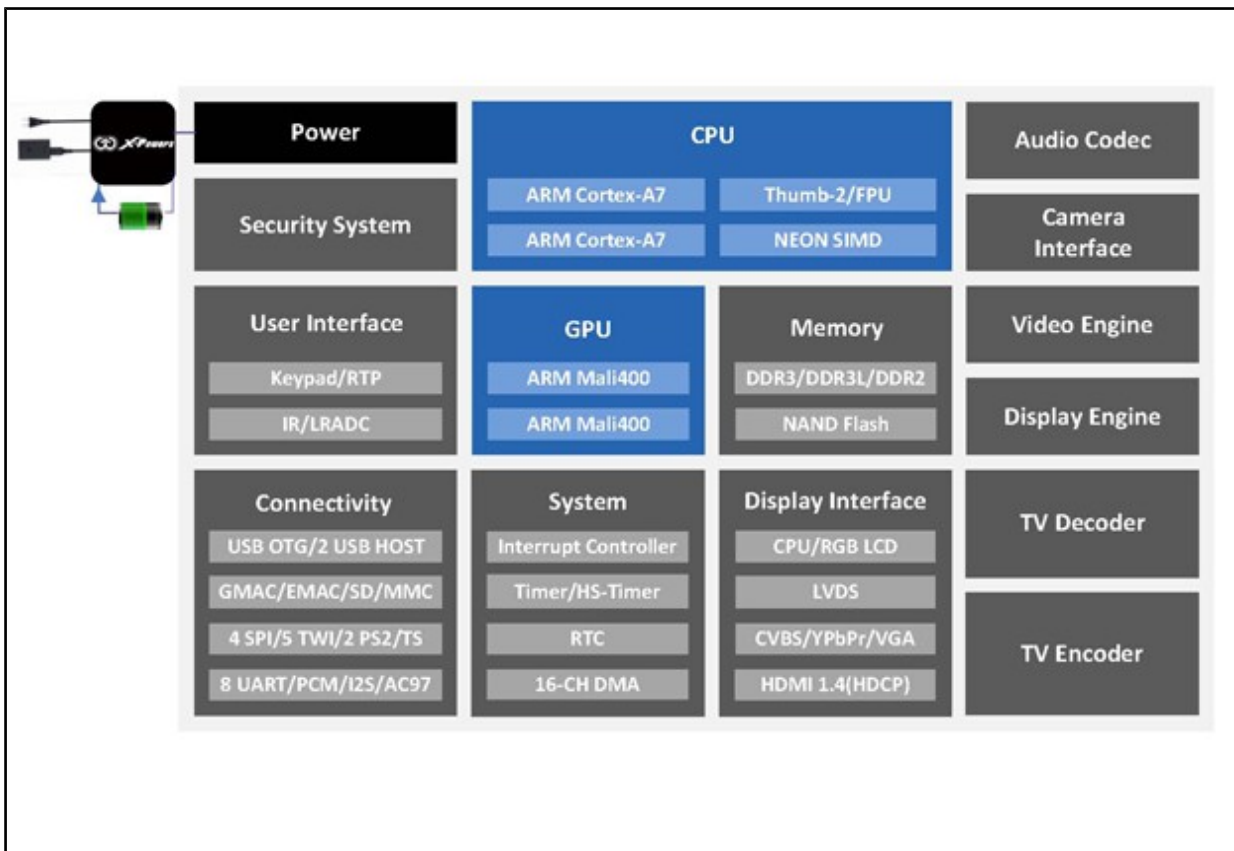

## CHAPTER 5: CONTROL CIRCUITY

---

### 5. Introduction to the chapter

---

Here you can find information about reset circuit and quartz crystals locations, the power supply circuit is also briefly discussed.

#### 5.1 Reset

---

The board has hardware reset controlled by the AXP209 power system management IC.

It is a good practice to perform software reset of the board. Performing reset by disconnecting the power supply might lead to software corruption of the operating system of choice.

#### 5.2 Clocks

---

32 768 Hz (RTC) quartz crystal Q1 is found at pins F1 and F2 of the A20 microcontroller.

24 MHz quartz crystal Q2 is found at pins N22 and N23 of the A20 microcontroller.

#### 5.3 Power supply circuit

---

The power supply is handled mainly by AXP209 power management system, an Allwinner chip that goes together with the A20 processor. It is mounted on the board but since it is relatively hard to find we also sell it separately (if you have provided over voltage and want to repair the board yourself).

A20-SOM typically consumes between 0.20A and 0.25A when connected to a 5V voltage source (provided at pins GND and 5VEXT).

During heavy load of the processor the consumption might raise up to 0.35A (tested with 'top d0').

The current consumed might have peaks as high as 0.50A during start-up when different modules are initialized.

Make sure your supply is capable of providing at least half an ampere of current at 5V of voltage.

For more info on how to power the board refer to chapter “2.3 Powering the board”.

## CHAPTER 6: CONNECTORS AND PINOUT

---

### 6. Introduction to the chapter

---

In this chapter are presented the connectors that can be found on the board all together with their pinout and notes about them. Jumpers functions are described. Notes and info on specific peripherals are presented. Notes regarding the interfaces are given.

#### 6.1 Communication with A20-SOM in Linux

---

The direct access method to the Linux command interface is via the serial interface. You would need to use the pins of the UART0 and then use your favorite terminal program (puTTY, minicom, picocom, teraterm, etc) to access the command line interface of the debian the data/send commands. You can use USB-SERIAL-CABLE-F with the UART0 interface that allows you to connect to a personal computer with a free USB port.

If you decide to make your own cable you would need to consider that the levels at board's UART0 are in CMOS level (3.3V) and you would need a convertor to bring them to the TTL level of your computer or cable! That is true for the RX and TX also!

It is highly recommended to have an USB-SERIAL-CABLE-F (or similar product) at hand when debugging – the video output is not always reliable and if you set wrong display settings you might be unable to recover the settings without a proper UART0 connection.

For more information please refer to chapter “2.5 Interacting with the board”.

#### 6.2 UART0 pins

---

The UART0 interface might be used for serial communication between the board and a personal computer by default. In the case of a video output problem a cable might provide the needed feedback and greatly reduce the efforts needed to repair the board or to adjust the software setting.

Note that by default only UART0 is defined as a port suitable for serial debug. You can use our USB-SERIAL-CABLE-F for debugging.

Even when A20-SOM is mounted on A20-SOM-EVB the default debug port remains UART0 (despite that it gets additional pins on the big board also for easier access).

UART0		
Pin #	Signal name	Processor pin
1	UART0-TX	A7
2	UART0-RX	B7
3	GND	-POWER CIRCUIT-
4	GND	-POWER CIRCUIT-
5	5VEXT	-POWER CIRCUIT-



Consider the table on the previous page when connecting the USB-SERIAL-CABLE-F, remember to refer to the wire color code. The RX line of the cable (GREEN wire) should go to TX line of the target board; the TX line of the cable (RED wire) should go to the RX line of the target board. The BLUE wire should go to the target's GND line.

## 6.3 MicroSD card connector

The micro SD card slot is primarily used for booting the operating system.

The board works with micro SDHC cards up to 32GB of storage.

As a general precaution be careful with the SD cards you purchase. There is a big percentage of fake cards due to the low effort required to counterfeit popular brands and the big demand for SD cards worldwide. When in doubt – try the same operation with another card from another brand.

Olimex sells microSD cards with Linux or Android images, that have been tested – please refer to chapter “2.2 Requirements”. Of course, if you already have a large enough microSD card you can download the official Linux image from the wiki pages: <https://www.olimex.com/wiki/A20-SOM>.

When removing the card, please make sure that you release it from the connector by pushing and NOT by pulling the card directly (this can damage both the connector and the microSD card).

### 6.3.1 SD/MMC slot

The schematic related to the SD/MMC (microSD connector) is shown below.

SD/MMC slot is a microSD card slot connector, located on the top of the board.

This slot is typically used for booting the OS, due to the larger capacities of the microSD cards (compared to SD or MMC cards). It is suggested to have an SD card with a proper Linux/Android image especially if you have ordered a version of the board without NAND memory. It is recommended to use Class 10 (10MByte/sec) card for faster read/write operations, since lower class cards (especially higher capacity ones) might slow down the whole system.

You can also find the table with the pinout of the microSD connector on the next page.

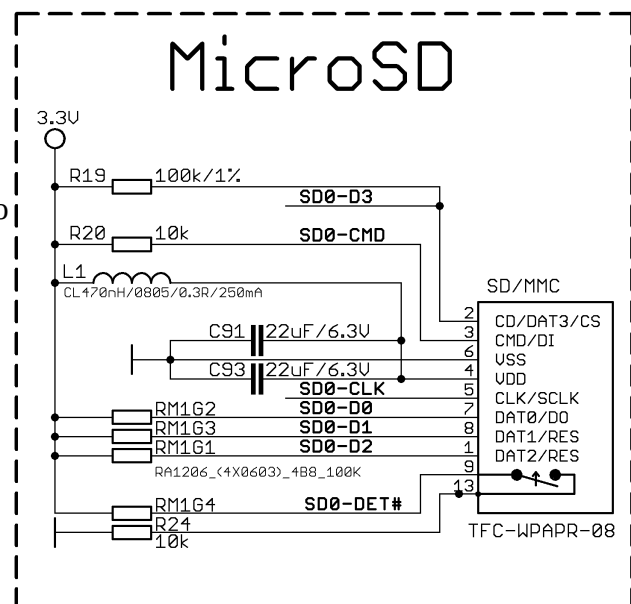

SD/MMC connector		
Pin #	Connector signal name	Wire name (processor pin)
1	DAT2/RES	SD0-D2 (K19)
2	CD/DAT3/CS	SD0-D3 (K20)
3	CMD/DI	SD0-CMD (L19)
4	VDD	SD_VCC
5	CLK/SCLK	SD0-CLK (L20)
6	VSS	GND
7	DAT0/DO	SD0-D0 (M19)
8	DAT1/RES	SD0-D1 (M20)
9	CARD DETECT (SYMBOL)	SD0-DET# (B6)
13	GND	GND

## 6.4 Power pins for external power supply

The recommended way of powering the board are the power pins located on the UART0 connector. They are suitable for 5V DC external power supply unit. The required current may vary depending on the peripherals connected to the board. The power supply should be capable of providing at least 0.5A of current.

The UART0 connector features also the pins suitable for serial communication with the board. For the powering, we are only interested in pins 5VEXT and the pin next to it – GND.

The signal names are printed under the pins, make sure to inspect the names before connecting the supply.

More info about the power supply can be found in chapter 5 of this manual.

## 6.5 GPIO connectors

There are 6 GPIO connectors located on the top side of A20-SOM. They ease the access to processors pins. These connectors (except for GPIO-6) also provide a way to mount the board to a board with peripherals.

**Important:** boards revisions prior to revision C have only 5 x GPIO connectors. The 14-pin GPIO-6 connector is not available.

Below you would find tables with the signal at each pin. To understand better what each processor pin does it might be a good idea to refer to the datasheet of the A20 processor. The schematic of the board of peripherals A20-SOM-EVB might also help you identify the main function of the pins.

To keep the form factor as small as possible the GPIO connectors have 0.05" step.

**IMPORTANT:** the connectors are very fragile – if you attempt to disconnect the board by pulling only one side out it might break! Furthermore – you might bend the board's pins! Use pliers or other suitable object to disconnect the connectors carefully!



OLIMEX sells additional and replacement male and female 0.05" (50 mil) step connectors. We also have a suitable cable named CABLE-40-40-10CM.

The only power line at the GPIO connectors that might be used as input is the one named '5VEXT'. The rest of the power signals are outputs and it would be incorrect to try to power the board from there.

### 6.5.1 GPIO-1 (General Purpose Input/Output) 40pin connector

GPIO-1 connector					
Pin #	Signal name	Processor pin	Pin #	Signal name	Processor pin
1	+5V	-POWER CIRCUIT-	2	GND	-POWER CIRCUIT-
3	+3.0VA	-POWER CIRCUIT-	4	AGND	-POWER CIRCUIT-
5	+5V_OTG_PWR	-POWER CIRCUIT-	6	LINEINR	AB21
7	USB0-DRV	C12	8	LINEINL	AB20
9	USB0-VBUSDET	C5	10	HPOUTR	W19
11	USB0-IDDET	B5	12	HPOUTL	Y19
13	USB1-DRV	A4	14	HPCOM	AA19/AA20
15	USB2-DRV	A5	16	MICROPHONE	-MIC CIRCUIT-
17	UDP0	N21	18	MIC1OUTP	AC22
19	UDM0	N20	20	MIC1OUTN	AC23
21	UDP1	P21	22	MICIN2	AC21
23	UDM1	P20	24	LRADC0	AB23
25	UDP2	R21	26	LRADC1	AB22
27	UDM2	R20	28	TVIN0	AC18
29	PI0	A20	30	TVIN1	AB18
31	PI1	B20	32	TVOUT3	AB17
33	PI2	A19	34	VGA-R	AC17
35	PI3	B19	36	VGA-B	AB16
37	PI10	C17	38	VGA-G	AC16
39	PI11	D17	40	PI14	C15

## 6.5.2 GPIO-2 (General Purpose Input/Output) 40pin connector

GPIO-2 connector					
Pin #	Signal name	Processor pin#	Pin #	Signal name	Processor pin#
1	5VEXT	-POWER CIRCUIT-	2	GND	-POWER CIRCUIT-
3	BAT	-POWER CIRCUIT-	4	GND	-POWER CIRCUIT-
5	SATA-TXP	T20	6	HTX2P	T23
7	SATA-TXM	T21	8	HTX2N	T22
9	SATA-RXM	U20	10	HTX1P	U23
11	SATA-RXP	U21	12	HTX1N	U22
13	HCEC	P23	14	HTX0P	V23
15	HSCL	R23	16	HTX0N	V22
17	HSDA	R22	18	HTXCP	W23
19	HHPD	P22	20	HTXCN	W22
21	UART0-TX	A7	22	UART0-RX	B7
23	ERXD0	E6	24	ETXD0	E8
25	ERXD1	D6	26	ETXD1	D8
27	ERXD2	E5	28	ETXD2	E7
29	ERXD3	D5	30	ETXD3	D7
31	ERXDV	D10	32	ETXEN	E11
33	ERXCK	E12	34	PA14	D14
35	PA9	E9	36	ETXCK	E12
37	EMDC	E10	38	CLK125	D13
39	EMDIO	EMDIO	40	EPHY_RST#	C13

### 6.5.3 GPIO-3 (General Purpose Input/Output) 40pin connector

GPIO-3 connector					
Pin #	Signal name	Processor pin#	Pin #	Signal name	Processor pin#
1	+5V	-POWER CIRCUIT-	2	GND	-POWER CIRCUIT-
3	3.3V	-POWER CIRCUIT-	4	GND	-POWER CIRCUIT-
5	PH0/SDC3-DET#	A6	6	PB3	B14
7	PH2/LED	C6	8	PB4	A13
9	PH8	C4	10	PB5	B13
11	PH9	D4	12	PB6	A12
13	PH10	A3	14	PB7	B12
15	PH11	B3	16	PB8	A11
17	PH12/CSI-STY-1	C3	18	PB10	C11
19	PH13/CSI-RST-1	A2	20	PB11	C10
21	PH14	B2	22	PB12	C9
23	PH15	A1	24	PB13	B11
25	PH16	B1	26	PB14	A10
27	PH17	C1	28	PB15	B10
29	PH18	C2	30	PB16	A9
31	PH19	D1	32	PB17	B9
33	PH20	D2	34	PH24	E3
35	PH21	D3	36	PH25	E4
37	PH22	E1	38	PH26	F3
39	PH23	E2	40	PH27	F4

### 6.5.4 GPIO-4 (General Purpose Input/Output) 40pin connector

GPIO-4 connector					
Pin #	Signal name	Processor pin#	Pin #	Signal name	Processor pin#
1	5VEXT	-POWER CIRCUIT-	2	GND	-POWER CIRCUIT-
3	3.3V	-POWER CIRCUIT-	4	LD03_2.8V	-POWER CIRCUIT-
5	TWI0-SK	A15	6	PE0/CSI0_PCLK	E23
7	TWI0-SDA	B15	8	PE1/CSI0_MCLK	E22
9	PE7/CSI0_D3	B22	10	PE2/CSI0_HSYNC	D23
11	PE8/CSI0_D4	A23	12	PE3/CSI0_VSYNC	D22
13	PE9/CSI0_D5	A22	14	PE4/CSI0_D0	C23
15	PE10/CSI0_D6	B21	16	PE5/CSI0_D1	C22
17	PE11/CSI0_D7	A21	18	PE6/CSI0_D2	B23
19	UART7-TX	E14	20	UART7-RX	E13
21	PB18/TWI1-SCK	A8	22	PB19/TWI1-SDA	B8
23	SPI1-MISO	D14	24	SPI1-MOSI	E15
25	SPI1-CLK	E16	26	SPI1-CS0	E17
27	UART6-TX	C16	28	UART6-RX	D16
29	TWI2-SCK	C8	30	TWI2-SDA	C7
31	SPI2-MISO	J20	32	SPI2-MOSI	J21
33	SPI2-CLK	K21	34	SPI2-CS0	L21
35	GPIO1	-AXP209-	36	PI15	D15
37	GPIO2	-AXP209-	38	NMI_N	F5
39	GPIO3	-AXP209-	40	RESET_N	C14

### 6.5.5 GPIO-5 (General Purpose Input/Output) 40pin connector

GPIO-5 connector					
Pin #	Signal name	Processor pin#	Pin #	Signal name	Processor pin#
1	PG0	F20	2	GND	-POWER CIRCUIT-
3	PG1	F21	4	SDC3-D0	A17
5	PG2	E20	6	SDC3-D1	B17
7	PG3	D21	8	SDC3-D2	A16
9	PG4	D20	10	SDC3-D3	B16
11	PG5	C21	12	SDC3-CMD	A18
13	PG6	E19	14	SDC3-CLK	B18
15	PG7	C20	16	PC16/CAM-PWR-EN	M21
17	PG8	D19	18	PC17/NWP	F23
19	PG9	C19	20	PC18	F22
21	PG10	D18	22	PC23	G19
23	PG11	C18	24	PC24/NQS	F21
25	NDQ0	H23	26	PC7/NRB1	J22
27	NDQ1	H22	28	NRB0	J23
29	NDQ2	G23	30	NRE	K22
31	NDQ3	G22	32	PC3/SATA-PWR-EN	L22
33	NDQ4	H21	34	NCLE	L23
35	NDQ5	H20	36	NALE	M22
37	NDQ6	G21	38	NWE	M23
39	NDQ7	G20	40	NCE0	K23

### 6.5.6 GPIO-6 (General Purpose Input/Output) 10pin connector

This connector was added in hardware board revision C. It is missing in board revisions A and B.

It has some points that might be used as test pads. Also couple of signals that might be used to debug the power supply.

GPIO-6 connector					
Pin #	Signal name	Processor pin#	Pin #	Signal name	Processor pin#
1	FMINL	Y20	2	TVIN2	AA17
3	FMINR	Y21	4	TVIN3	Y17
5	VMIC_OUT	USED FOR MIC	6	AXP_BACKUP	GOES TO AXP209
7	IPSOUT	COMES FROM AXP209	8	AXP_RST	GOES TO AXP209
9	UBOOT_SEL	W8	10	AXP_PWRON	GOES TO AXP209
11	VDD_RTC	COMES FROM AXP209	12	GND	-POWER CIRCUIT-
13	TP1	FREE	14	TP2	FREE

## 6.6 LCD\_CON 40pin connector

The LCD\_CON pins are led out on a separate 40pin connector for the ease of connecting an LCD. The step of the connector of A20-SOM is still 0.5". We have tested the ability of the board to interact with such a display. They allow the user to attach additional hardware, check readings or perform hardware debug.

Important: you would probably need an additional adapter board and two different 40PIN ribbon cables to connect an Olimex display and the LCD\_CON. The evaluation board RK3188-SOM-EVB provides a 0.1" step LCD connector which eases the hardware interfacing between the board and the display.

The LCD connector is suitable (but not plug-and-play due to the different pin-step) for a number of Olimex displays and touchscreen panels with different native resolution – the smallest available is the **4.3"** one called **LCD-OLinuXino-4.3TS** with native screen resolution of **480×272**, through the **7"** one named **LCD-OLinuXino-7TS** with **800×480**, to the **1024×600 10.1" LCD-OLinuXino-10TS**.

Note that the smallest display (4.3", 480×272) is not suitable for the official Android images we provide.

Full list of recommended displays for the board might be found in chapter “2.7 Connecting and calibrating a display”.

LCD_CON connector					
Pin #	Signal name	Processor pin	Pin #	Signal name	Processor pin
1	+5V	-	2	GND	-
3	3.3V	-	4	GND	-
5	LCD_D16	Y12	6	LCD_D17	AA12
7	LCD_D18	Y11	8	LCD_D19	AA11
9	LCD_D20	Y10	10	LCD_D21	AA10
11	LCD_D22	AB12	12	LCD_D23	AC10
13	LCD_D8	AB11	14	LCD_D9	AC11
15	LCD_D10	Y15	16	LCD_D11	AA15
17	LCD_D12	Y14	18	LCD_D13	AA14
19	LCD_D14	Y13	20	LCD_D15	AA13
21	LCD_D0	AB15	22	LCD_D1	AC15
23	LCD_D2	AB14	24	LCD_D3	AC14
25	LCD_D4	AB13	26	LCD_D5	AC13
27	LCD_D6	AB12	28	LCD_D7	AC12
29	LCD_HSYNC	AB9	30	LCD_VSYNC	AC9
31	LCD_CLK	Y9	32	LCD_DE	AA9
33	PB3	B14	34	PB4	A13
35	PH7/LCD_PWR	B4	36	PB2/PWM0	A14
37	TPX1	Y22	38	TPX2	AA22
39	TPY1	Y23	40	TPY2	AA23

## 6.7 Jumper description

Please note that two jumpers on the board are SMT type. If you feel insecure of your soldering/cutting technique it is better not to try to adjust the jumpers since it is possible to damage the board.

Board jumpers			
Jumper name	Type	Default position	Function
NAND_E	SMT	Either CLOSED or OPEN, depending whether the board has 4GB NAND MEMORY MODULE	Controls whether the NAND memory module is enabled or disabled.  If the jumper is closed than the NAND memory is operational.  By default it should be set properly for your board.
5V_E	SMT	OPEN	The jumper is used for internal testing. It is not recommended to change its position. When the jumper is closed it removes a circuit that handles cases in which you provide power supply to both +5V and 5VEXT power lines.

## 6.8 Additional hardware components

The components below are mounted on the A20-SOM but are not discussed above. They are listed here for completeness:

**Reset button** – used to reset the board

**Power button** – used to power up the board

**Recovery button** – used to wake-up the board (from power down state)

**1GB = 2×[4Gb (256 M x 16 bit) DDR3 SDRAM]** – the exact memory used currently is SAMSUNG K4B4G1646D-BCK0 – the memory clock in board revisions A and B of A20-SOM was 384MHz; the memory clock in hardware revisions C, D and newer ones is improved to 480MHz

The DDR3 memory part name in the schematic might be outdated. We have used a number of different but fully compatible DDR3 memories due to supply unavailability. It is always recommended to check the exact memory name printed on the component itself.

**4GB = 1×[32Gb (4096 M x 8 bit) NAND FLASH]** – only available on the 4GB version of the board; the exact memory used in the board revision mentioned is HYNIX H27UBG8T2A

PWR\_LED – turns on upon powering the board

CHGLED – lights when charging a battery connected to the Li-Po battery connector.

# CHAPTER 7: SCHEMATICS

## 7. Introduction to the chapter

In this chapter is located information about the schematics describing logically and physically A20-SOM.

### 7.1 Eagle schematic

A20-SOM schematics may be found it on the OLIMEX's GitHub repository: <https://github.com/OLIMEX/SOM/tree/master/A20>. You can download the whole repository as .zip without having a GitHub account.

The part of the design that has the main microcontroller is considered proprietary design and design files would not be shared.

If you are looking for a schematic of an older revision of the board and it isn't available at our web site you may request it by the support e-mail.

### 7.2 Physical dimensions

Note that all dimensions are in mils.

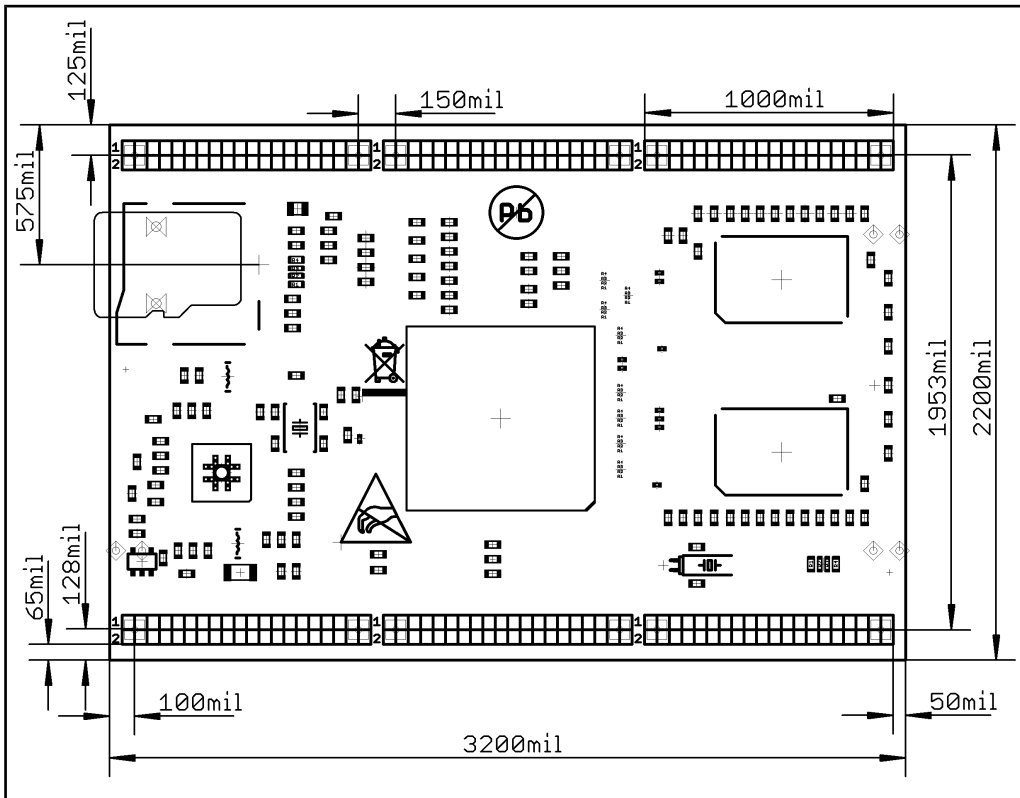



## CHAPTER 8: REVISION HISTORY AND SUPPORT

### 8. Introduction to the chapter

In this chapter you will find the current and the previous version of the document you are reading. Also the web-page for your device is listed. Be sure to check it after a purchase for the latest available updates and examples.

### 8.1 Document revision

Document revision	Changes	Modified page
A, 08.10.14	- Initial manual release	All
B, 18.11.14	- Cleared duplicate information - Updated the information about the LCD displays	7, 15
C, 26.11.14	- Improved LCD display information	12, 14
D, 19.12.14	- Adjusted for board revision D changes	17, 30
E, 30.01.15	- Fixed wrong information about the inner pin of the power jack	10
F, 09.02.2015	- Fixed information about the CMOS-TTL convertor	21
G, 10.02.2015	- Added information about SSH connection via miniUSB connector and VGA video	11
H, 17.03.2015	- Updated FAQ - Updated electrical polarity warning - Updated DDR3 memory according to the latest schematic	8, 30, 36, 37, 38
I, 27.03.2015	- Multiple minor errors were fixed - Multiple stylistic mistakes were fixed	8, 11, 21, 22, 23

## 8.2 Board revision

Remember to check the schematics and the board design files to compare the differences.

Board revision	Notable changes
A	Initial release of the board
B	<ol style="list-style-type: none"><li>1. Optimized values</li><li>2. Resolved various multiplexing issues</li><li>3. Renamed few wires properly</li></ol>
C	<ol style="list-style-type: none"><li>1. Major routing and layout differences with previous hardware revisions! General hardware improvement of the board based on A20-OLinuXino-Lime2_Rev_B's memory routing. General layout improvement. Additional GPIO connector.</li><li>2. Added GPIO-6 connector with the following signals FMINL, FMINR, TVIN2, TVIN3, VMIC_OUT, AXP_BACKUP, AXP_RST, AXP_PWRON, UBOOT_SEL, VDD_RTC and GND;</li><li>3. Various value optimizations</li><li>4. Memory clock now upped to 480Mhz (from 384Mhz)</li></ol>
D	<ol style="list-style-type: none"><li>1. Added VGA resistor matrix</li><li>2. Minor hardware optimizations adjustments</li></ol>

### 8.3 Useful web links and purchase codes

---

The web pages you can visit for more information about A20-SOM are:

<https://www.olimex.com/Products/SOM/A20/A20-SOM/> and  
<https://www.olimex.com/Products/SOM/A20/A20-SOM-4GB/>.

A20-SOM-EVB's web page is here: <https://www.olimex.com/Products/SOM/A20/A20-SOM-EVB/open-source-hardware>

Wiki article of the board: <https://www.olimex.com/wiki/A20-SOM>

A place for general questions, FAQ or friendly talk: <https://www.olimex.com/forum/>.

You can get the latest updates on the software at:  
<https://github.com/OLIMEX/SOM/tree/master/A20>.

You may may join our IRC channel #olimex @ freenode.net (<http://webchat.freenode.net/?channels=olimex>).

The sunxi community is behind the Allwinner Linux support: [http://linux-sunxi.org/Main\\_Page](http://linux-sunxi.org/Main_Page).

#### ORDER CODES:

**A20-SOM** – the product for which this manual is about

**A20-SOM-EVB** – A20-SOM-4GB + a shield with all important peripherals (HDMI port, Gigabit interface, SATA port, Headphones jack, Microphone jack, Camera, etc)

**USB-SERIAL-CABLE-F** – USB serial console cable female

**A20-SOM-Android-SD** – a tested class 10 micro SD card with the latest (by the time of leaving the Olimex facilities) official Android release

**A20-SOM-REV-D-DEBIAN-SD** – a tested, class 10 micro SD card suitable for A20-SOM boards revision C or newer; with latest (by the time of leaving the Olimex facilities) official Debian release

**A20-SOM-DEBIAN-SD** – a tested, class 10 micro SD card suitable for A20-SOM boards revision A and revision B; with latest (by the time of leaving the Olimex facilities) official Debian release

**LCD-OLINUXINO-4.3TS** – low-cost 4.3" LCD display with touchscreen component – 480×272

**LCD-OLINUXINO-7TS** – low-cost 7" LCD display with optional touchscreen component – 800×480

**LCD-OLINUXINO-10TS** – low-cost 10" LCD display with optional touchscreen component – 1024×600

**LCD-OLINUXINO-15.6** – low-cost 15.6" LCD display – 1366×768

**LCD-OLINUXINO-15.6FHD** – low-cost Full HD 15.6" LCD display – 1920×1080

**ALUMINIUM-HEATSINK-20×20×6MM** – heatsink radiator for better processor heat dissipation

**How to purchase?**

You can purchase directly from our online shop or from any of our distributors. Note that usually it might be faster and cheaper to purchase Olimex products from our distributors. List of confirmed Olimex LTD distributors and resellers: <https://www.olimex.com/Distributors>.

Please visit <https://www.olimex.com/> for more info.

---

## 8.4 Frequently asked questions

---

### **Q: I powered my board, it showed a logo and then nothing happened. What might be the problem?**

---

A: This might be due to a number of reasons but it is recommended to try the following:

1. Download latest official image from our wiki (either Android or Debian for SD card), and upload it to an SD card again. There are instructions how to do it in the other questions below. Try if the board works now.
2. Check if your power supply provides enough current, try with different/better power supply.
3. Check the USB hub you are using, plug the USB cable directly to the back of your personal computer, check the USB cable.
4. The board might enter sleep mode very fast (especially if the Android was turned off without the "Quick Boot" mode being ticked on). Try pressing or holding down the PWR button for a couple of seconds to wake it up.

### **Q: How do I write the Linux image to a micro SD card to use with my A20 board?**

---

A: First visit the wiki article for the board and download the archive with the image. Then write the Linux image to a microSD card.

Under Windows we use Win32 Disk Imager: <http://sourceforge.net/projects/win32diskimager/>

Download Win32 Disk Imager software

Insert card

Start program

Select file

Click "write"

To write a Linux image to an SD card under Linux:

For instance, an image with the file name of "debian\_2g.img" would be downloaded to a microSD card connected to a Linux machine using one of the following commands:

```
# dd bs=4M oflag=sync if=debian_2g.img of=/dev/sdX
```

or

```
# cp debian_2g.img /dev/sdX
```

where X is the uSD card.

The tips above can also be used to prepare a microSD card with an Android image, suitable for a microSD card.

**Q: How to edit board configurations and definitions in the official Debian Linux?**

---

A: Do you want a custom video resolution output? Do you need a different port definition? Do you need to change the hardware definitions of the board?

It is explained above in the manual. But you can also visit this wiki article: [wiki article](#).

**Q: How to edit board configurations and definitions in the official Android images?**

---

A: There is a wiki article about that, please visit: [wiki article](#).

**Q: Is it possible to boot Debian from NAND? Do you provide such image?**

---

A: It is possible but we don't provide such image. There are people who were successful in booting Debian from the NAND, however. Make sure to check on the forum.

**Q: How to generate boot-able SD-card Debian Linux image for A20-SOM?**

---

Build instructions and required files for the latest Debian images: [GitHub location](#)

Note that Linux-Sunxi Kernel is a work-in-progress, this means you can try the current stage/sunxi-x.x branch but if something is broken and doesn't work just revert to the git tags we give in the blog and they would work for sure.

[Sunxi u-boot loader](#) – the linux-sunxi git page contains a lot of sources for all Olimex Allwinner boards.

**Q: How to detect and enable the Ethernet controller (if it is disabled by default)?**

---

A: You can enable it by following these two steps:

1. To check under what name the LAN is associated write "ifconfig -a"
2. If, for example, it is under eth0 name, then write: "dhclient eth0"

This should enable the Ethernet and then SSH would also be available.

You can also enable auto detection of Ethernet on power-up by removing the comment #auto eth0 in /etc/network/interfaces in the Linux image.

**Q: How to download the prebuilt Android image to a microSD card?**

---

A: First download one of the official Android images, which might be found in the Android section above.

Make sure that the download link you visit clearly indicates that the image is suitable for the microSD card since there are images suitable for NAND memory also. The images suitable for the microSD memory and those suitable for NAND card are different. However, the upload method is almost identical – using PhoenixSuit.

There are two types of Android images for microSD card that we usually provide and each of them has to be downloaded to a microSD card using a different method. The image provided for microSD card is either the native Android image that can be downloaded to the card via a software tool like

PhoenixSuit (through the board) or an image taken from an already prepared microSD card that requires to simply write the image (through a microSD card reader).

It is more likely that you have an Android image that requires a simple copy to a card. If that is the case you can follow the exact steps as for Linux (e.g. using "Win32 Disk Imager" or "dd" command).

In order to prepare a microSD card with a native Android you will need a software tool called PhoenixSuit and then:

- Install and run PhoenixSuit.
- Go to the firmware tab of the program and point to a valid Android image (note that the images on Google drive are compressed and you have to extract the archives to .img files to be able write them with PhoenixSuit)
- Disconnect the power supply and USB cable from the A20 board. Put an SD card in micro SD holder. We recommend 4GB class 10 card.
- Press and hold RECOVERY button, apply power supply (the requirement various depending on whether you use the board stand-alone or on top of A20-SOM-EVB), release RECOVERY button.
- Connect USB cable to the mini USB connector.
- You will be asked for drivers for the boot-loader. Navigate to the folder where you extracted the PhoenixSuit and install the drivers from the respective executables (or manually point the installer to the drivers folder in the PhoenixSuit installation path).
- PhoenixSuit will detect the board and would ask for the method of writing the image. Choose method of writing the image and confirm your wish to write the image.
- Wait till upgrade succeeds

Note that it is not recommended to have your mini USB connected to an external USB hub. This might cause delays and might distort the signal levels. Always test with the USB connected straight to the USB ports of your computer.

Important: When Android runs for very first time it takes several minutes to initialize all files and buffers please do not cut the power supply during this process! Also when fresh image is installed fast boot may be disabled, which means that when you apply power supply after few seconds Android will go in sleep mode and you have to press PWR button to start it, you can change to fast boot when you power off there is dialog box asking you if you want next boot to be fast boot, you have to check this box before you power off. Also note that you must do touch screen calibration when you run Android for very first time which might require a mouse.

### **How to download Android image to the NAND memory of my A20 board?**

---

To repair the image on the NAND re-upload it following these steps:

1. Install and run PhoenixSuit (can be found here: [google drive](#)).
  2. Download and extract the latest official image from the Android section of the wiki: [A20-SOM article](#). Make sure that the download link you visit clearly indicates that the image is suitable for the NAND memory since there are images suitable for microSD card also. The images suitable for the microSD memory and those suitable for microSD card are different. However, the upload method is almost identical – using PhoenixSuit.
  3. Go to firmware tab of the program and point to the already downloaded and extracted Android
-

image.

4. Disconnect the power supply and USB cable from the A20 board.
5. Press and hold RECOVERY button, apply power supply (the requirement varies depending on whether you use the board stand-alone or on top of A20-SOM-EVB), release RECOVERY button.
6. Connect USB cable to the mini USB connector.
7. You will be asked for drivers for the bootloader. Navigate to the folder where you extracted the PhoenixSuit and install the drivers from the respective executable (or manually point the installer to the drivers folder in the PhoenixSuit installation path).
8. PhoenixSuit will detect the board and would ask whether you wish to also write the image. Choose method of writing the image and confirm your wish to write the image.
9. Wait till upgrade succeeds

Note that it is not recommended to have your mini USB connected to an external USB hub. This might cause delays and might distort the signal levels. Always test with the USB connected straight to the USB ports of your computer.



## 8.5 Product support

---

For product support, hardware information and error reports mail to: [support@olimex.com](mailto:support@olimex.com). All document or hardware feedback is welcome. Note that we are primarily a hardware company and our software support is limited. Please consider reading the paragraph below about the warranty of Olimex products.

All goods are checked before they are sent out. In the unlikely event that goods are faulty, they must be returned, to OLIMEX at the address listed on your order invoice.

OLIMEX will not accept goods that have clearly been used more than the amount needed to evaluate their functionality.

If the goods are found to be in working condition, and the lack of functionality is a result of lack of knowledge on the customers part, no refund will be made, but the goods will be returned to the user at their expense.

All returns must be authorized by an RMA Number. Email [support@olimex.com](mailto:support@olimex.com) for authorization number before shipping back any merchandise. Please include your name, phone number and order number in your email request.

Returns for any unaffected development board, programmer, tools, and cables permitted within 7 days from the date of receipt of merchandise. After such time, all sales are considered final.

Returns of incorrect ordered items are allowed subject to a 10% restocking fee. What is unaffected? If you hooked it to power, you affected it. To be clear, this includes items that have been soldered to, or have had their firmware changed. Because of the nature of the products we deal with (prototyping electronic tools) we cannot allow returns of items that have been programmed, powered up, or otherwise changed post shipment from our warehouse.

All returned merchandise must be in its original mint and clean condition. Returns on damaged, scratched, programmed, burnt, or otherwise 'played with' merchandise will not be accepted.

All returns must include all the factory accessories which come with the item. This includes any In-Circuit-Serial-Programming cables, anti-static packing, boxes, etc.

With your return, enclose your PO#. Also include a brief letter of explanation of why the merchandise is being returned and state your request for either a refund or an exchange. Include the authorization number on this letter, and on the outside of the shipping box.

Please note: It is your responsibility to ensure that returned goods reach us. Please use a reliable form of shipping. If we do not receive your package we will not be held liable.

Shipping and handling charges are not refundable. We are not responsible for any shipping charges of merchandise being returned to us or returning working items to you.

The full text might be found at <https://www.olimex.com/wiki/GTC#Warranty> for future reference.

---

---

---