

## Sonos LED Beacon (DC)

A general purpose beacon. Features the TimeSaver base where connections are made to the base during the initial wiring phase which results in faster and more reliable installation. The beacon head 'twists and clicks' into the base on commissioning, avoiding the wiring and connection problems associated with traditional alarm devices.

Deep base units have weatherproof protection to IP65 and can be used in all locations both indoors and outdoors. The Sonos Beacon utilises a full faced, translucent case which provides a much larger lens area and a greater spread of light.

Sonos Beacon units have a deep or shallow red colour base as standard and are available with a red or amber lens.

### Features

- High efficiency LED beacon consumes less than 5mA
- Simple 'First Fix' installation (no second fix wiring)
- Weatherproof to IP65 (deep base units)
- Synchronised flash

### Lens Colour Options



**Applications** - Fire; security; industrial alarm

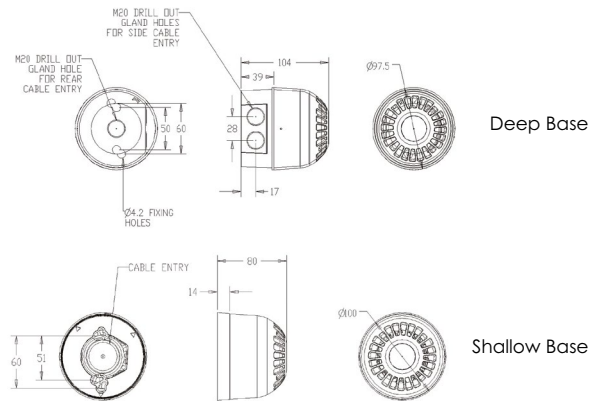

## Specifications

Part No.	Base	Colours	Voltage	Current
PSB-0009	Red shallow base	Red lens	17-60V DC	5mA
PSB-0026	Red shallow base	Amber lens	17-60V DC	5mA
PSB-0017	Red deep base	Red lens	17-60V DC	5mA
PSB-0031	Red deep base	Amber lens	17-60V DC	5mA
PSB-0042	White shallow base	Clear lens, Red LED	17-60V DC	5mA
PSB-0045	White deep base	Clear lens, Red LED	17-60V DC	5mA
PSB-0048	White shallow base	Red lens	17-60V DC	5mA
PSB-0050	White shallow base	Amber lens	17-60V DC	5mA
PSB-0035	White deep base	Red lens	17-60V DC	5mA
PSB-0036	White deep base	Amber lens	17-60V DC	5mA

**IP Rating:** IP65 (deep base) IP21 (shallow base)  
**Operating Temp:** -25°C to +70°C  
**Construction:** Flame Retardant Polycarbonate  
**Cable Entries:** 2 x 20mm cable glands (deep base)  
**Weight:** 0.22kg (shallow base) 0.25kg (deep base)